

# MODULAR DIGITAL 7-HOLE PROBE SYSTEM

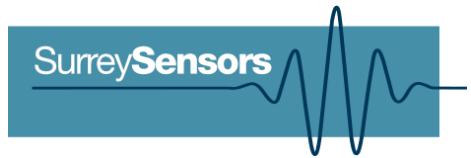

This fully self-contained, high-precision and robust flow measurement solution provides a compact, low-cost alternative to optical flow diagnostics. Ideal for use in wind-tunnel, UAV and motorsport applications, this probe offers industry-leading functionality at a fraction of the cost of comparable systems.

The modular structure enables probe stings to be interchanged, for fast replacement in case of damage and the option of using a variety of sting architectures with a single sensor package.

- Flow speed ranges possible from 1.1 m/s – 100 m/s at standard conditions
- Three components of velocity obtainable
- Modular structure enables sting to be changed within seconds avoiding the need for time-consuming repairs
- Local fluid temperature, humidity and absolute static pressure also measured
- Inertial positioning sensor for automatic alignment and vibration warning
- Low-profile, in-line sensor package measuring under 20 mm in diameter
- Option of integrated static pressure ring in the probe sting



## Specification

Standard sensor specifications (custom available on request)			
Product code	IDXHP-160P	IDXHP-1K0	IDXHP-6K9
Standard pressure ranges	160 Pa FS	1 kPa FS	6.9 kPa FS
Maximum overpressure	33.5 kPa	37.5 kPa	69 kPa
Sensor accuracy <sup>1</sup>	± 0.1 % FS		
Total error band after auto-zero <sup>2</sup>	± 0.5 % FS	± 0.25 % FS	± 0.25 % FS
Operational mode	Absolute and differential configurations available		
Compensated temperature range	-40° to +65° C	0° to +50° C	0° to +50° C
Operating temperature range	-40° to +65° C non-condensing		
Storage temperature range	-40° to +65° C non-condensing		
Vibration	Sensors rated to 15 g, 10 Hz to 2 Hz		
Maximum relative humidity	95 %		

# MODULAR DIGITAL 7-HOLE PROBE SYSTEM

Relative ambient humidity sensor specification	0 % to 100 % RH, +/- 3%
Ambient temperature sensor specification <sup>3</sup>	0°C - 65°C ± 0.5°C
Ambient absolute pressure sensor specification	30-110 kPa FS, +/- 0.1kPa

Standard probe specifications (custom available on request)		
Product code	ID7HP-XXX	ID8HP-XXX
Static pressure measurement	-	Integrated absolute pressure transducer
Reference pressure	Available either with static pressure ring on sting or connection to laboratory reference	
Standard sting material	Steel	CFRP
Sting diameter	3.7 mm or 12 mm	12 mm
Standard tip geometry	Hemispherical	Hemispherical
Angular measurement range <sup>4</sup>	± 45°	± 45°
Sting heater	-	Optional film heater located between sting tip and static ring
Sting tip temperature measurement	-	-80°C - 150°C ± 1°C
Remote temperature probe	-40°C - 150°C ± 0.5°C	2x -80°C - 150°C ± 1°C
Absolute temperature limits	5° to +65° C non-condensing	-80° to +65° C (expected) non-condensing <sup>5</sup>
Absolute pressure limits	0.2 - 1.5 atm	0 - 1.5 atm
Weight (approximate)	45 g	95 g
Voltage	6-24 VDC or via USB	6-24 VDC system 28 VDC sting heater
Power	min. 290 mW	min. 310 mW heater off/ 2310 mW heater on
Communications interface	USB2.0 & UART, RS232 or UDP Ethernet available	
Data acquisition rate	1 kHz (equivalent)	
Digital resolution	24-bit pressure, 16-bit environmental and IMU	
System requirements	Windows 7 or later, minimum 3GHz & 4Gb RAM	
IMU specification	3 axis gyro, 125 °/s FS, ± 3.9 x10 <sup>-3</sup> °/s 3 axis accelerometer, 2g FS, ± 0.061 mg	

<sup>1</sup> Includes errors due to pressure non-linearity, pressure hysteresis, non-repeatability and calibration uncertainty.

<sup>2</sup> Total residual error after auto-zero, excluding residual temperature sensitivity.

<sup>3</sup> Temperature is recorded at the location of the PCB. Waste heat from electronic components may distort temperature readings.

<sup>4</sup> Angular range specified for hemispherical tip; depends on tip geometry.

<sup>5</sup> Temperature limits are design limits, based on assumptions about heat transfer at high altitudes

# MODULAR DIGITAL 7-HOLE PROBE SYSTEM

## Additional custom modifications available:

- Variety of probe geometries available
- Probe diameters down to 2 mm
- Option of UAV probe in steel version
- External heating and cooling sleeves may be integrated for use in cryogenic or combustor applications
- Battery power and wireless telemetry module for remote operation
- Custom enclosure design service
- Custom software and driver development service
- Calibration service
- Extended product support and warranty
- Extended compensated temperature range

## Dimensions

**ID8HP** (Stings available in CFRP, 316 stainless or nylon, with or without heaters)

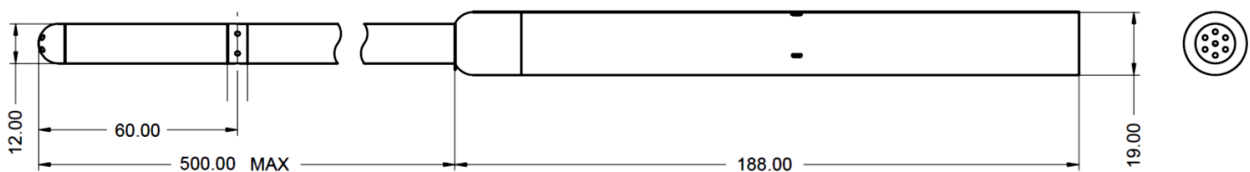

**ID7HP** (Stings available in 3.7 mm and 12 mm OD as standard, straight or 90°; custom geometries possible)

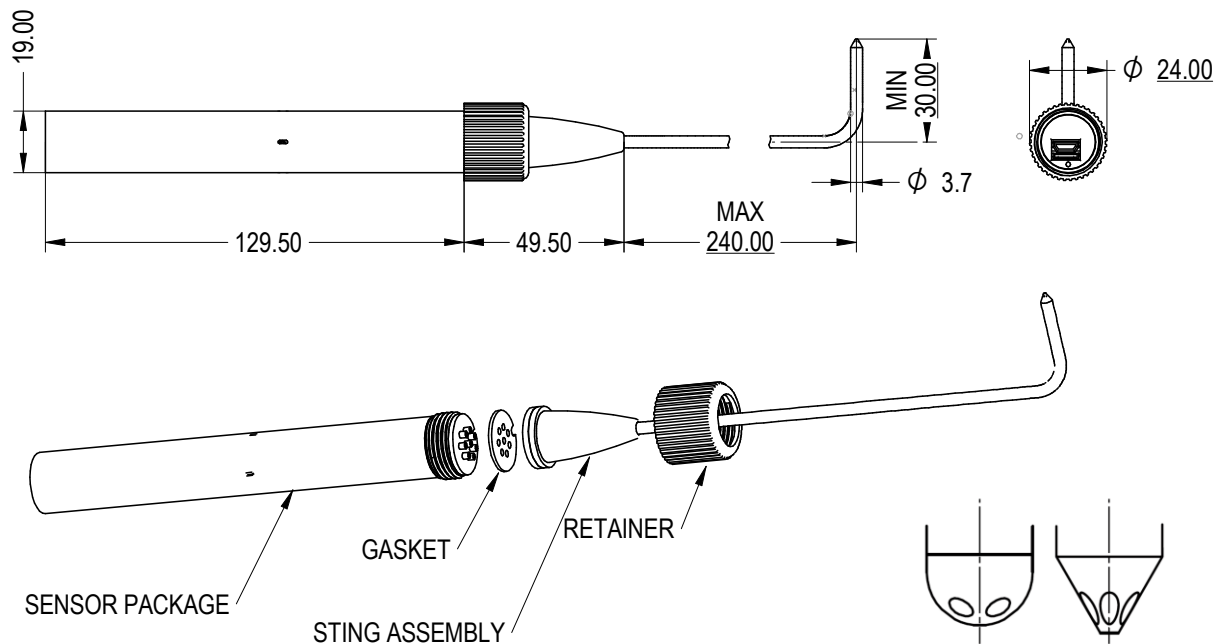

The content of this datasheet is for general information only and is subject to change without notice. It may contain inaccuracies or errors and Surrey Sensors Ltd. expressly exclude liability for any such inaccuracies or errors to the fullest extent permitted by law. Your use of any information is entirely at your own risk, for which Surrey Sensors Ltd. shall not be liable.